

Cooper Night Stand

How to build a night stand with a drawer.

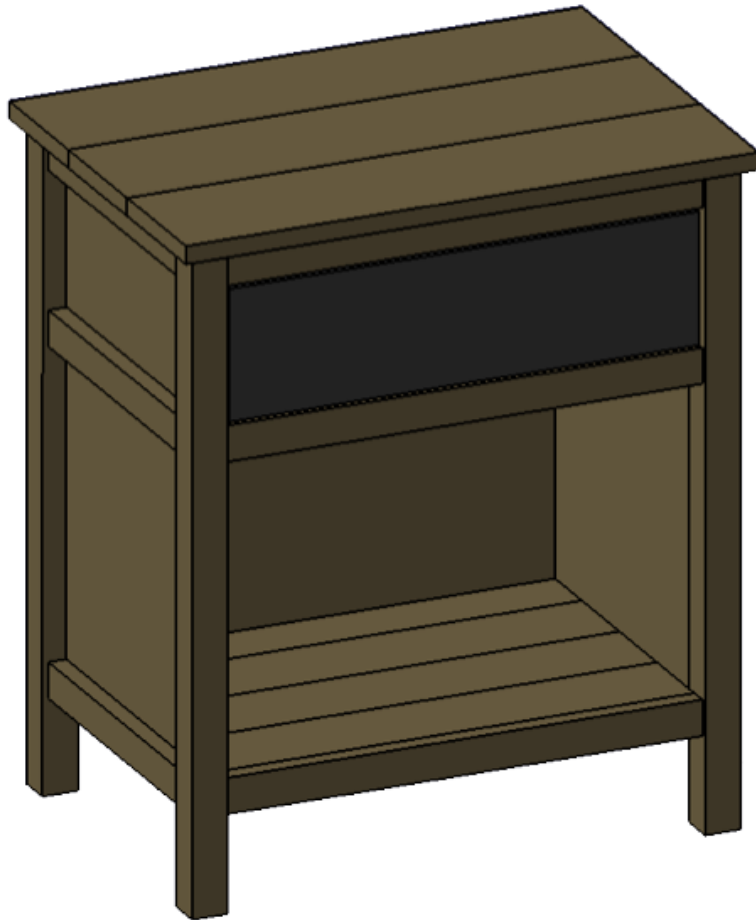

If your planning on staining this, I would recommend building it in red oak. I have tried to use materials that are convenient to most at the big box stores. You could always do it in a pine but from my experience, its worth the extra money to go with a hardwood for something like this.

Tools Required:

Measuring Tape
 Square
 Pencil
 Safety Glasses
 Hearing Protection
[Kreg Jig](#)
 Drill
 Circle Saw
 Level

Material List:

4x 2" x 2" x 36"
 3x 1" x 2" x 6'
 1x 1/2" x 24" x 48" (plywood)
 1x 1/4" x 24" x 48" (drawer bottom)
 1x 1" x 6" x 8'
 2x 1" x 4" x 6'
 Drawer Pull
 1-1/4" Pocket Hole Screws
 3/4" Wood Screws

Cut List:

Qty	Dimensions	Notes
4x	2 x 2 x 27.25"	
6x	1 x 2 x 20"	Only cut 2 pieces per 6' board
6x	1 x 2 x 12.5"	Only cut 2 pieces per 6' board
4x	1 x 4 x 20"	Only cut 2 pieces per 6' board
2x	1 x 4 x 13"	Only cut 1 piece per 6' board
2x	1 x 4 x 17.5"	Only cut 1 piece per 6' board
3x	1 x 6 x 24"	
1x	1 x 6 x 19.25"	
6x	3/4 x 1/2 x 12.5"	This can be cut using some leftover scrap
2x	1/2 x 12.5 x 23.25"	
1x	1/2 x 20 x 23.25"	
1x	1/4 x 12 x 17.5"	If you don't have a dado blade don't cut this yet

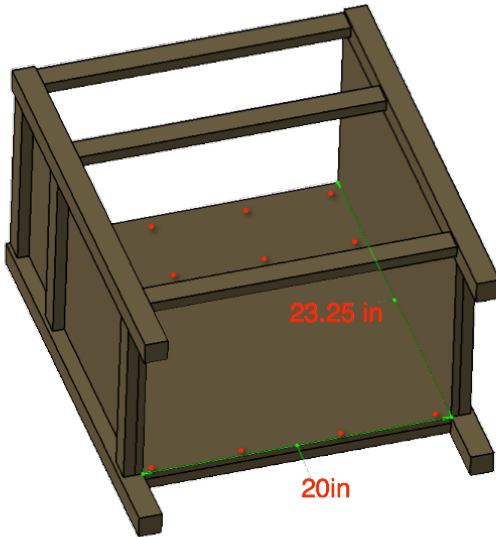

Step 4:

To finish off the box, screw and glue the $\frac{1}{2}$ "x20"x23.25" plywood back panel to the rear 1x2x20" boards with twelve $\frac{3}{4}$ " wood screws.

Make sure to wipe off any excess glue (Hint: Glue doesn't stain).

Step 5:

Add the rails for the drawer, as shown, leaving a $\frac{13}{16}$ " gap (just over $\frac{3}{4}$ ") to accept the rail on the drawer. Remember to pre-drill your holes and then screw and glue the rails in place, with $1\text{-}\frac{1}{4}$ " pocket hole screws.

Make sure to wipe off any excess glue (Hint: Glue doesn't stain).

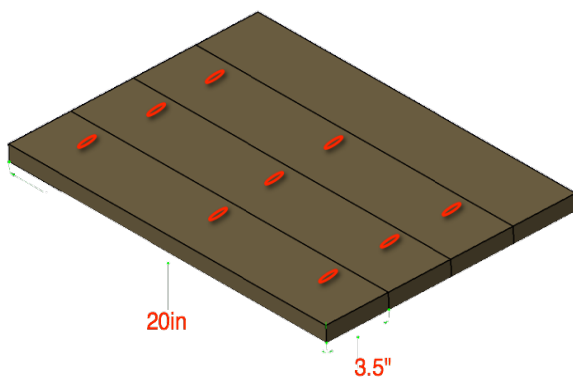
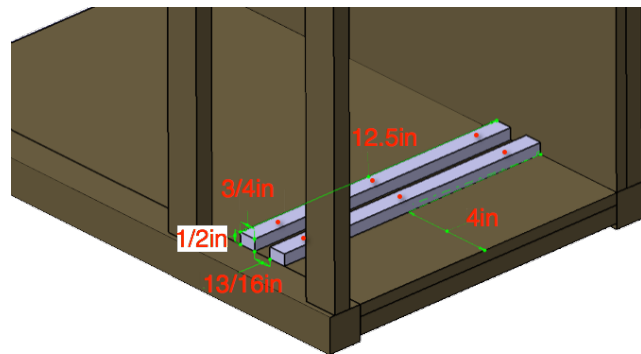

Step 6:

Assemble the lower shelf by drilling three pocket holes in three of the four 1x4x20" boards. Next, glue and screw one board at a time making sure to keep a flat shelf by clamping at each screw point.

(Note: If you have any 1x3 scrap handy, I suggest you substitute the last board for it, being as, in the next step we have to cut 1" off the back.)

Make sure to wipe off any excess glue (Hint: Glue doesn't stain).

Step 7:

Take the lower shelf that you have just assembled and cut 1" off the back.

Yes, I know you could have just used a 1x3, and if you had the scrap laying around you should have, but it doesn't make sense to buy a 1x3x6' just for this now does it?

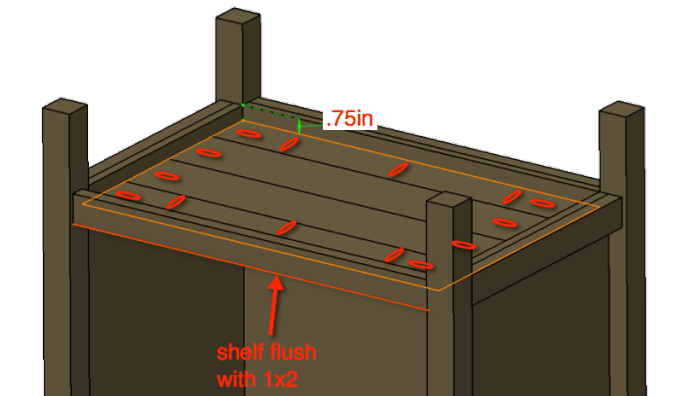
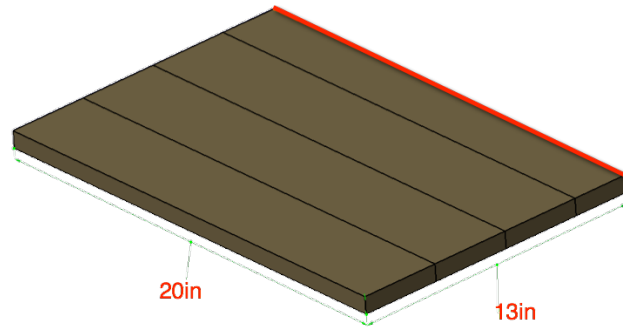
**Step 8:**

Drill pocket holes in each end of each board and then three along the front and back of the shelf.

Wedge the shelf in place. You should have $\frac{3}{4}$ " between the bottom of the shelf and the bottom of your frame. Also, make sure that the top of your shelf is flush with the 1x2 on the front, as shown in the picture.

Clamping everything together, screw the shelf in place, with 1- $\frac{1}{4}$ " pocket hole screws. You will notice that I didn't say anything about gluing. Well, trying to glue and wedge this shelf in place will make quite a mess and with this many screws hold the shelf in place I think it will be more than okay.

Step 9:

Now, on to the top. Drill three pocket holes in two of the three 1x6x24" boards. Making sure to keep your top as even as possible, glue and screw each board together. Make sure you clamp the boards by the hole when screwing together with 1- $\frac{1}{4}$ " pocket hole screws.

Make sure to wipe off any excess glue (Hint: Glue doesn't stain).

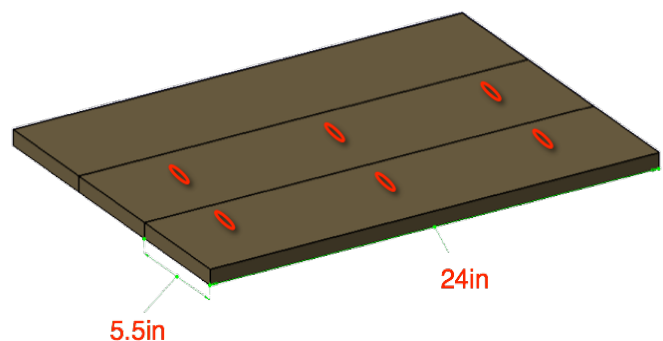

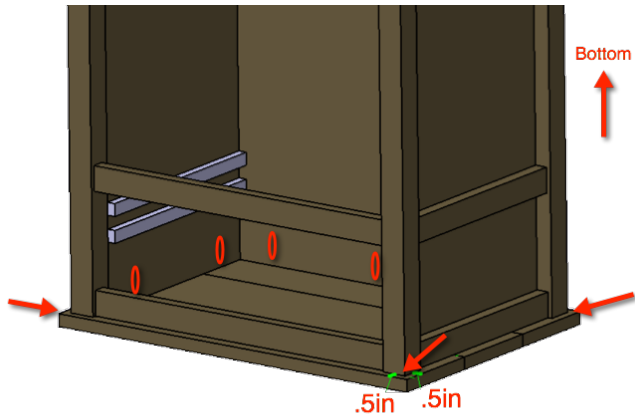

Step 10:

To attach your top, drill two or three pocket holes on the inside of all sides.

Keeping a 1/2" over-hang on all sides from the corner posts, screw and glue your top in place with 1-1/4" pocket hole screws.

Make sure to wipe off any excess glue (Hint: Glue doesn't stain).

Step 11:

Cutting the groove as shown in the sides, front and back of the box is really easy with a [dado blade](#). Or you can take two side by side passes with a table saw or circle set to a depth of 1/4".

Don't fret if you don't have a [dado blade](#) and this looks intimidating, just skip the groove. You can always make the bottom panel in the steps ahead large enough that you can just tack it to the bottom.

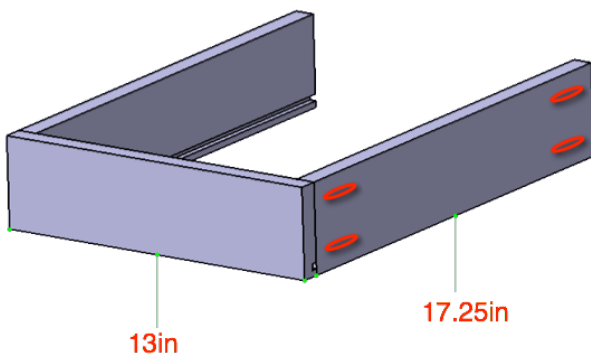
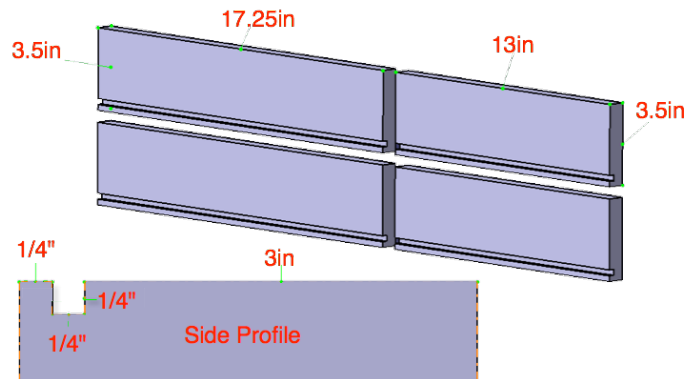

Step 12:

Drill two pocket holes in each end of the front and back boards (the longer ones!)

Now screw and glue **ONLY one side** with 1-1/4" pocket hole screws.

Make sure to wipe off any excess glue (Hint: Glue doesn't stain).

Step 13:

This is an easy one, just slide your 1/4" plywood (12"x17.75") in the groove.

Note: If you did not cut the groove you will need to make your drawer bottom 18.75"x13" and tack with finishing nails and .

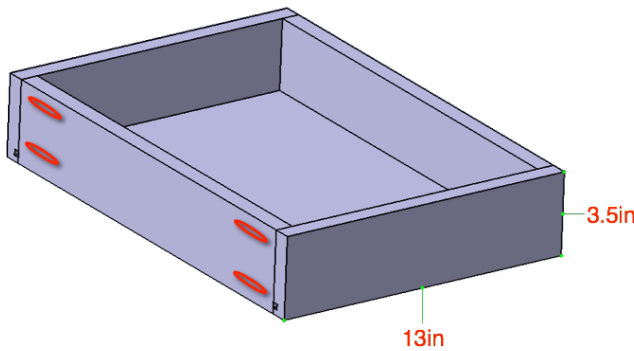
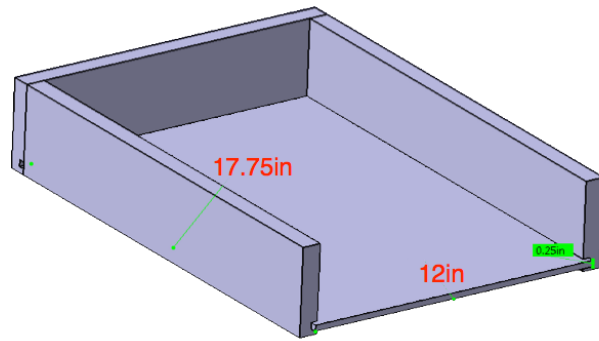

Step 14:

Now fit the last side in place and screw and glue it together with 1-1/4" pocket hole screws.

Make sure to wipe off any excess glue (Hint: Glue doesn't stain).

Step 15:

Now, with 3/4" wood screws, screw and glue the .5x.75x12.5" rails to the sides of the drawer. Make sure to keep one side flush to the front and maintaining 1.5" from the top of the drawer.

Make sure to wipe off any excess glue (Hint: Glue doesn't stain).

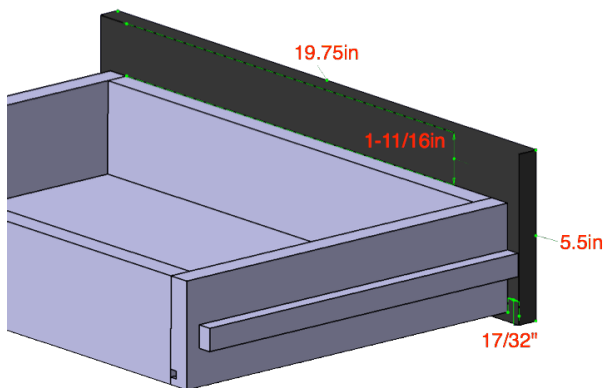
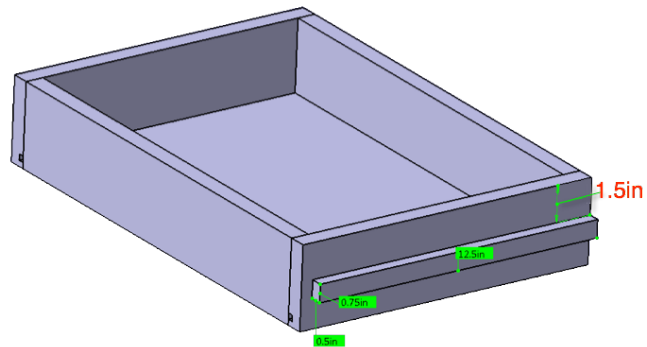

Step 16:

Finally, attach the 1x6x19.75" drawer front with two 1-1/4" wood screws.

Note: Depending on the drawer pull you picked out and the hardware it came with you may need to add the hardware to the drawer front beforehand.

Finishes:



For this project I choose the following combination stain:

- [Minwax Special Walnut](#)
- [Minwax Weathered Oak](#)
- [Rustoleum Weathered Gray](#)

As for a sealant, I went with 4 coats of [Rustoleum Zinsser Bulls Eye Shellac](#) on the nights stand and [Minwax Paste Finishing Wax](#) on the drawer front.

For other finishing ideas please take a look at our finishes page where my wife Jamie lays out, step-by-step how to's on different popular and beautiful finishes and techniques.