

DIY FARMHOUSE BENCH PLANS

Tools Required

Materials

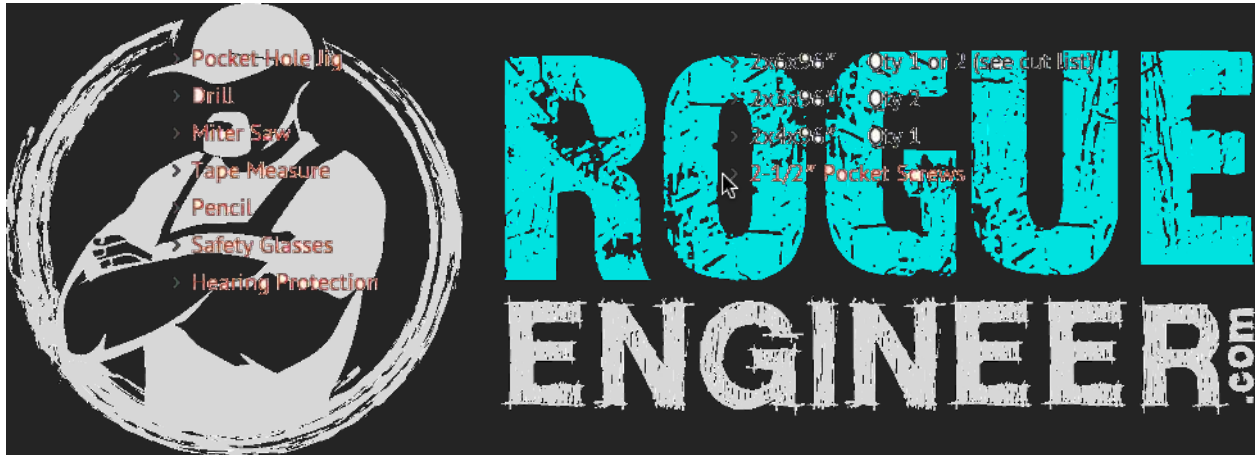

2 x 6 x 96" (stock)

Little short huh? I used some scrap from the table.
If you don't have any you'll need another board.



2 x 3 x 96" (stock)



2 x 4 x 96" (stock)



Straight cut only.
Miter details in step 1.

Step 1: Assemble Sides (Qty 2)

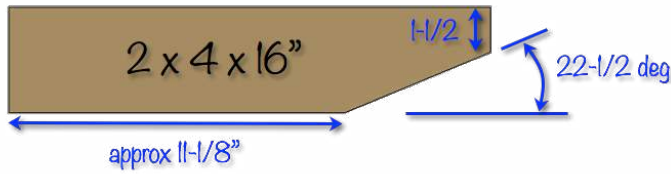

Drill **pocket holes** as shown for securing top in the future

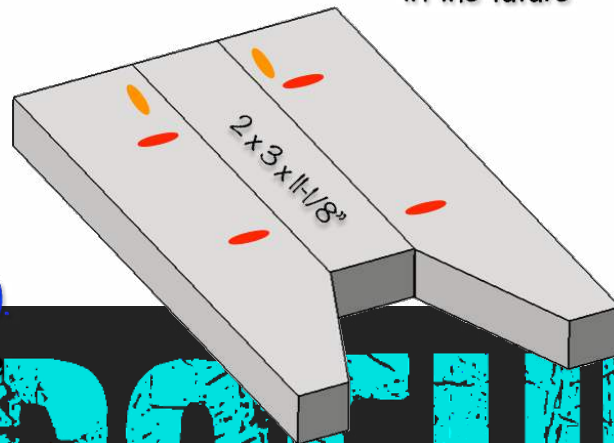

Miter 2x4s as shown (Qty 4).

Drill **pocket holes** and assemble using 2-1/2" pocket screws.

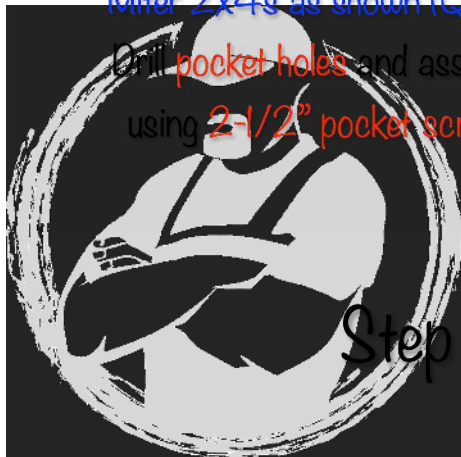

Step 2: Assemble Base

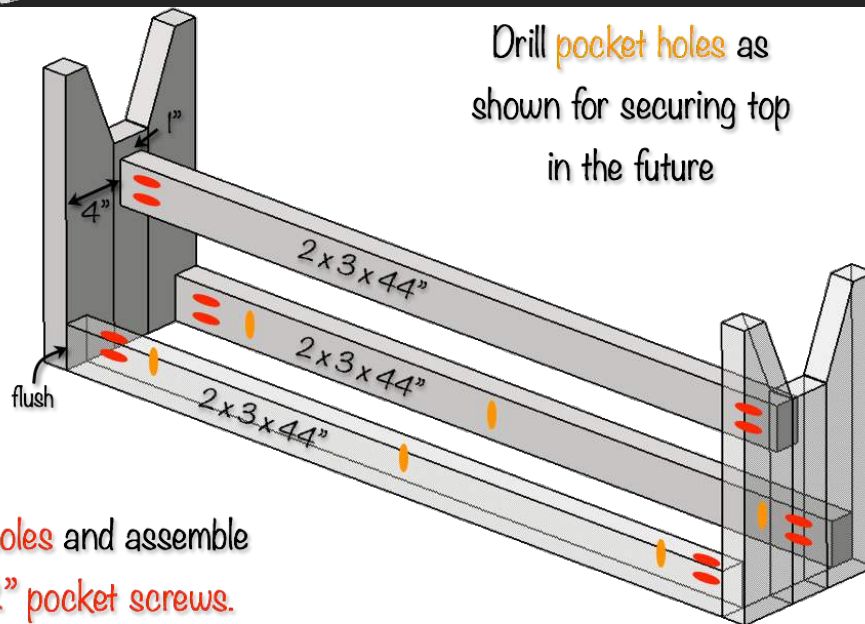

Drill **pocket holes** and assemble using 2-1/2" pocket screws.

Step 3: Assemble Top

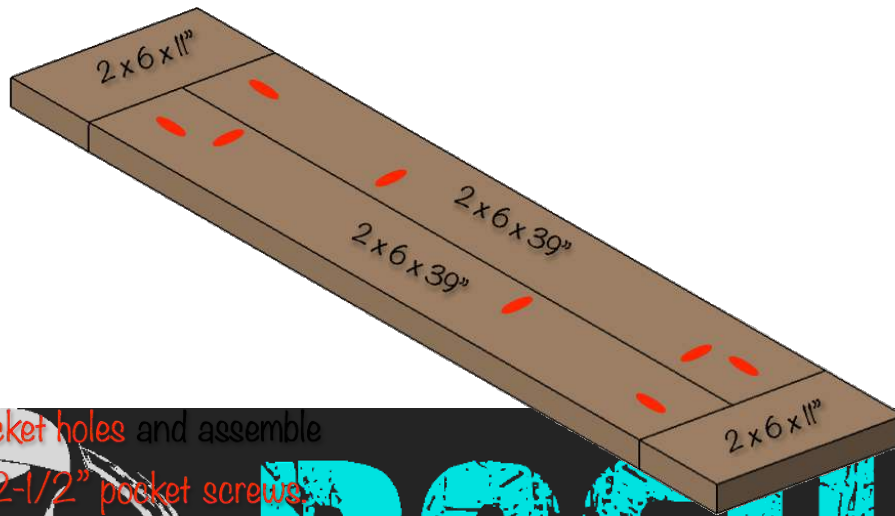

Drill pocket holes and assemble using 2-1/2" pocket screws.

Step 4: Assemble Bench

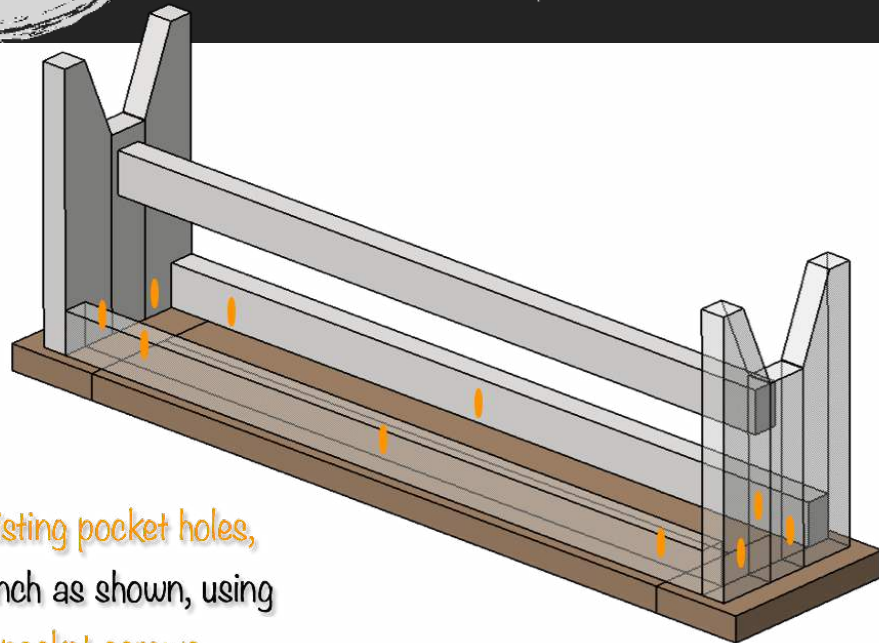

Utilizing existing pocket holes, assemble bench as shown, using 2-1/2" pocket screws