



**ROGUEENGINEER**.com

1 x 8 x 72"

(Qty 1)



1 x 6 x 72"

(Qty 1)



2 x 3 x 96"

(Qty 2)



# Step 1: Assemble Base

Drill **pocket holes** for **1-1/2"** thick material and **pocket holes** for **3/4"** thick material (top) as shown. Assemble base using **1-1/4"** pocket screws and **2"** wood screws.

**Remaining pocket holes** are for final assembly and screws should exit toward the bench top.

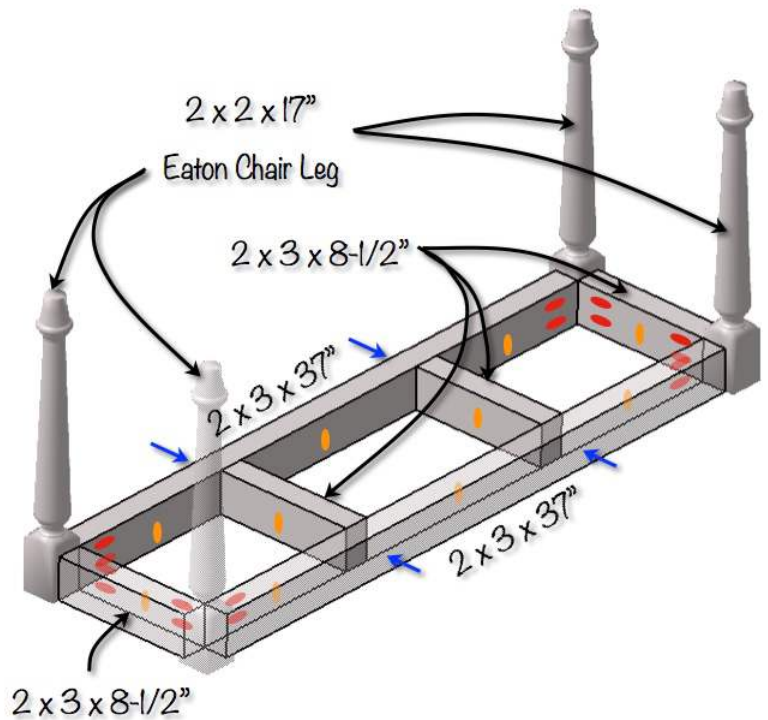

**ROGUEENGINEER**.com

# Step 2: Assemble Top

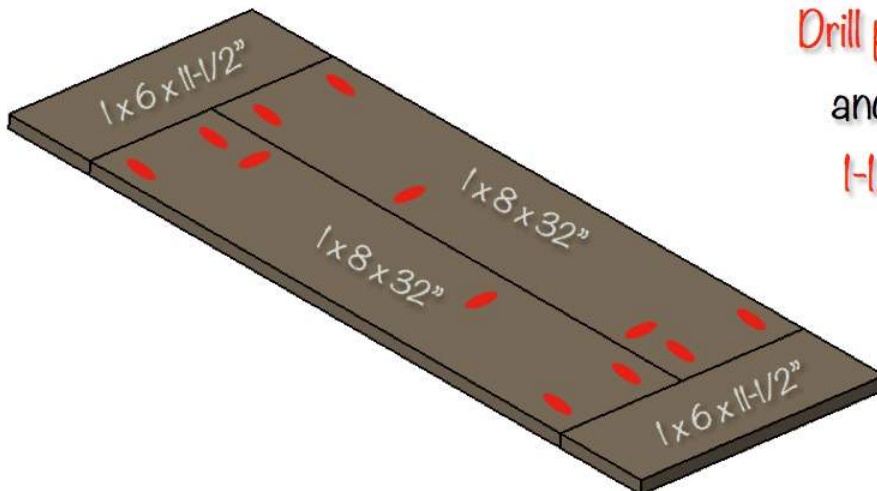

Drill **pocket holes** as shown and assemble top using **1-1/4"** pocket screws

# Finishing

After filling the screw holes on the sides and sanding everything we stained the top and the base with Early American wood stain from Rustoleum. Then Jamie applied Vaseline to the areas we wanted to distress. We then followed that with Zinsser's Stain Blocking Primer and flat white paint (not shown).

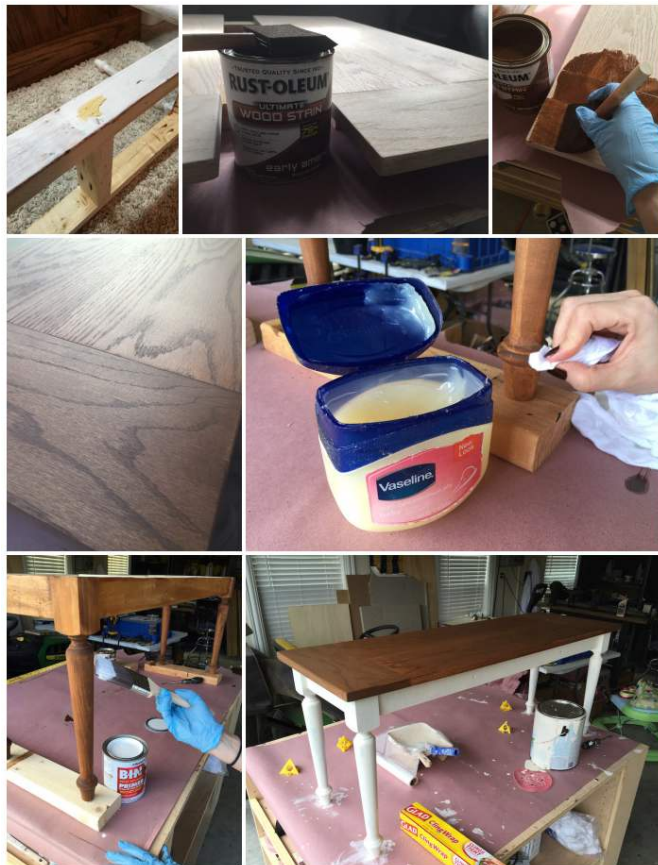

**ROGUEENGINEER**.com

## Step 3: Final Assembly

Utilize **existing pocket holes** in base and attach top using **1-1/4" pocket screws**.

