

Stacked Crate End Table

DIY Plans By:

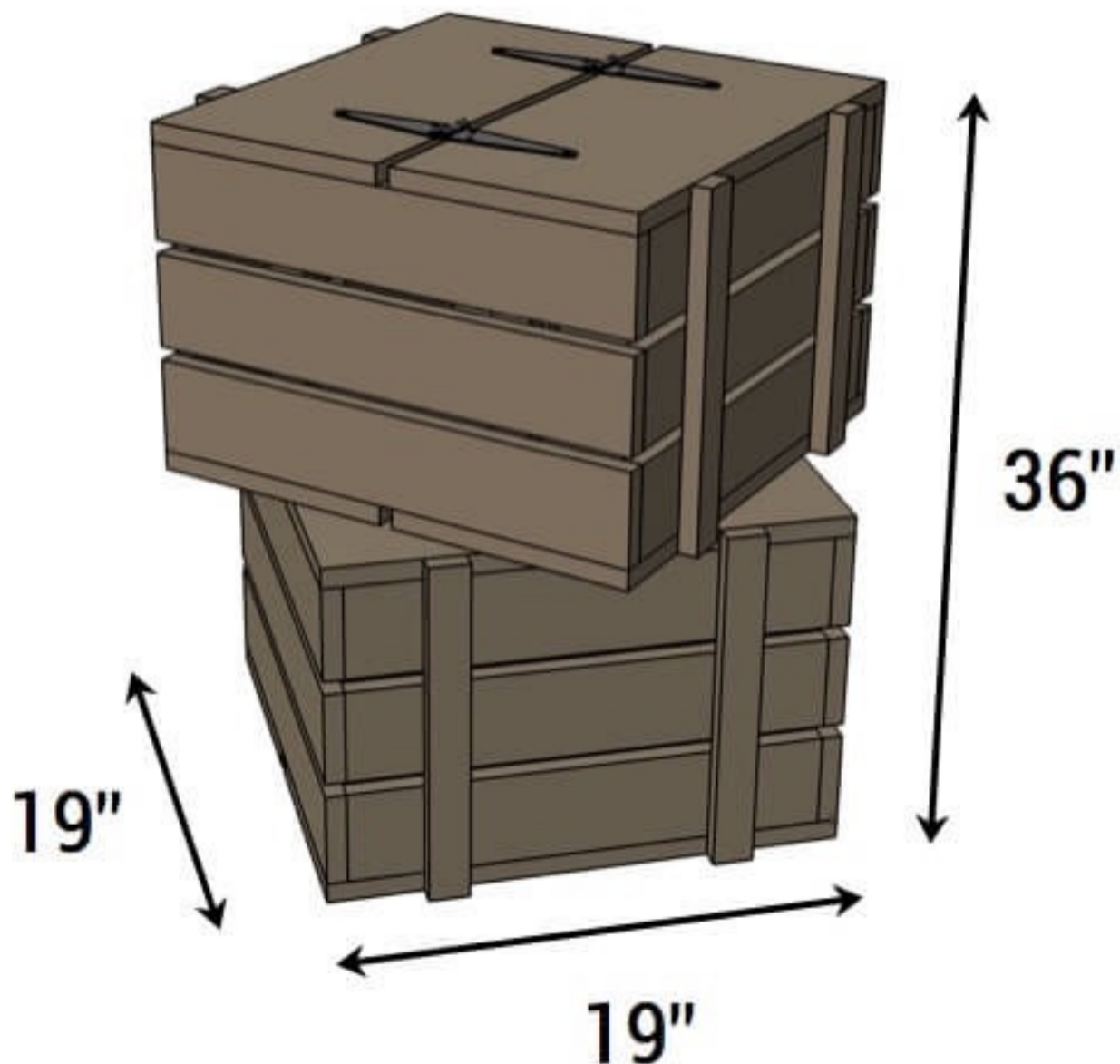

1 x 10 x 8' (Qty 2)



1 x 4 x 8' (Qty 5)

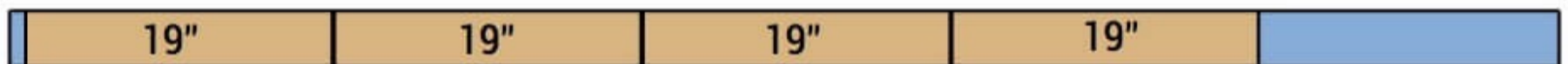
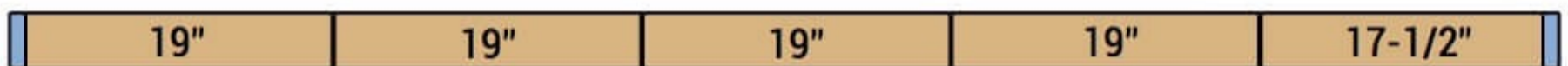
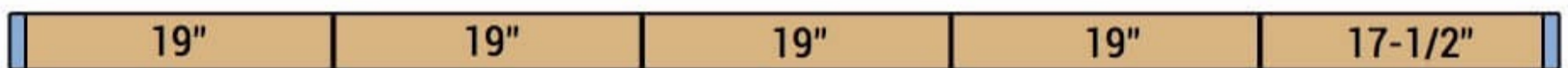
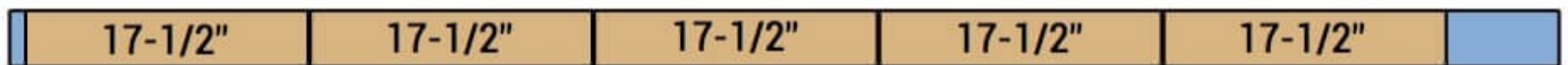
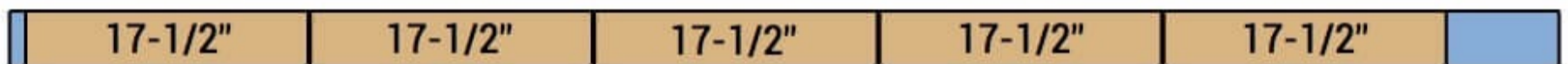

1 x 2 x 8' (Qty 3)

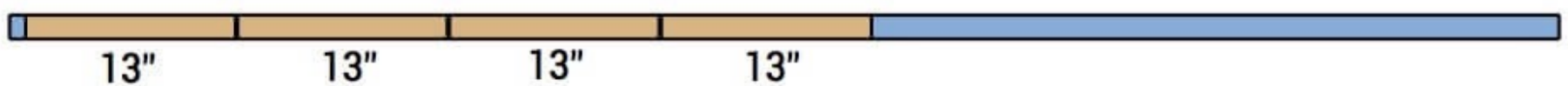
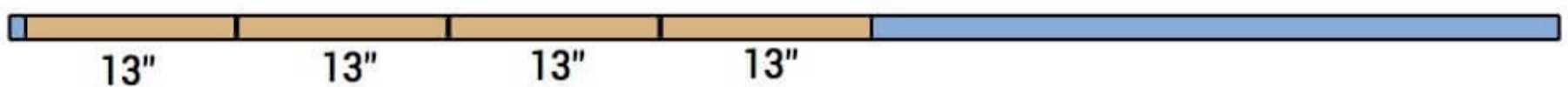
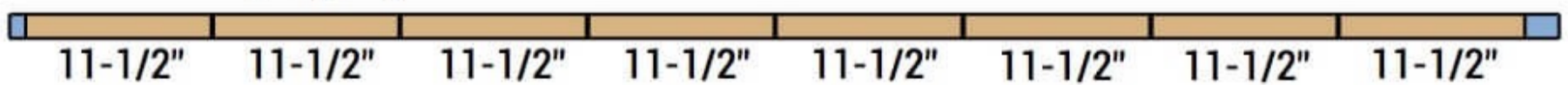

Step 1: Assemble Sides (4 ea)

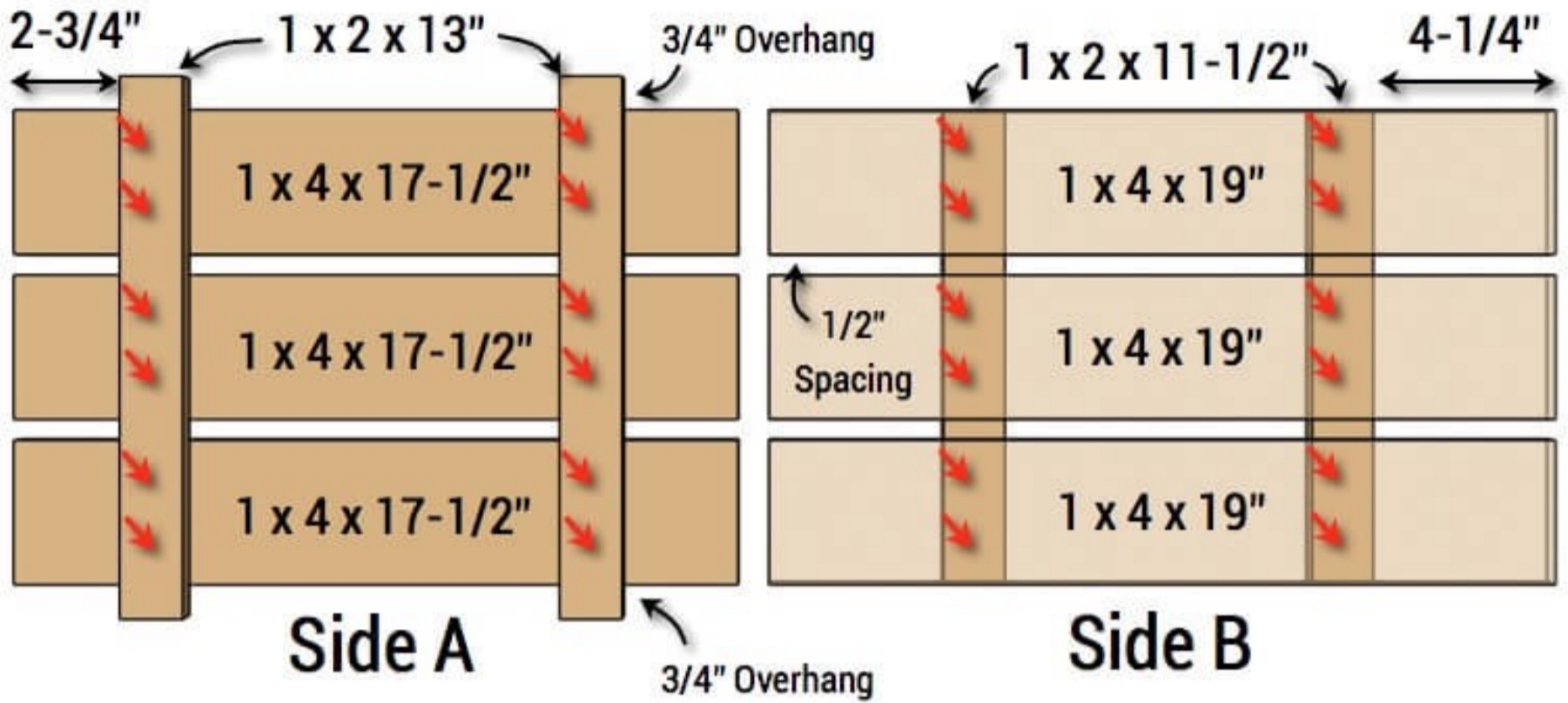

Assemble 4 of each, sides A and B, as shown using **1-1/4" wood screws**.



Step 2: Assemble Crate Sides (Qty 2)

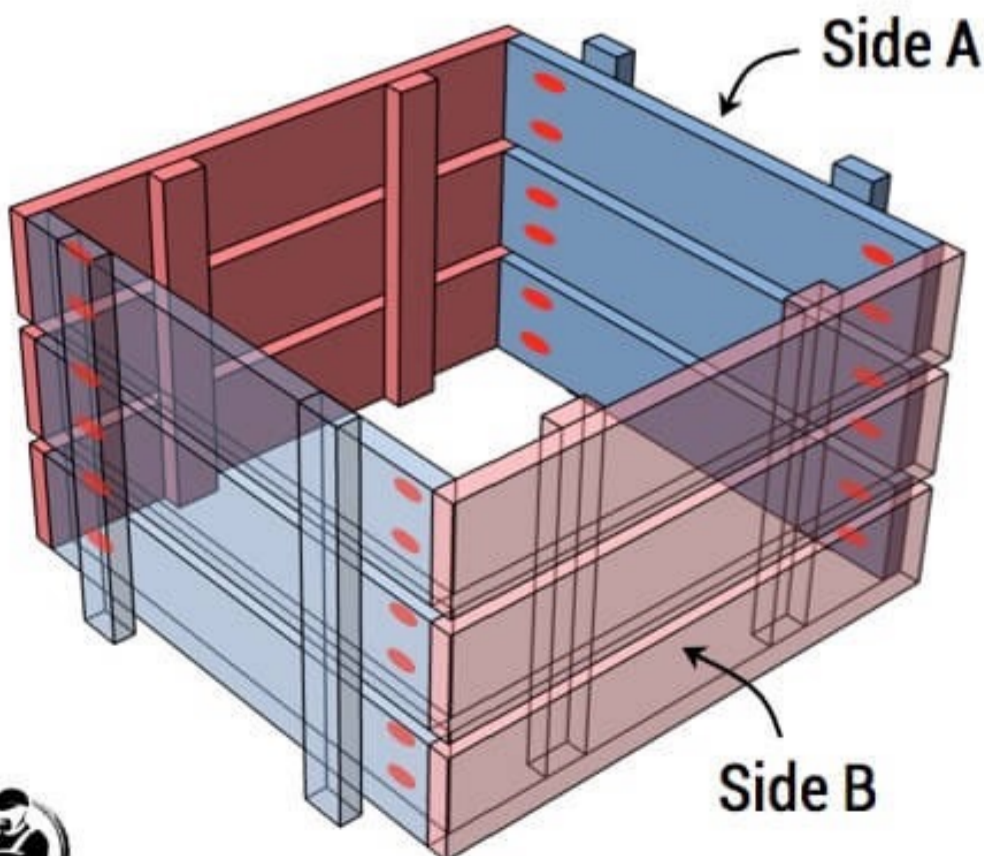

Drill **pocket holes** and assemble crates (qty 2) as shown using **1-1/4" pocket hole screws**.



Step 3: Install Top and Bottoms (Qty 2)

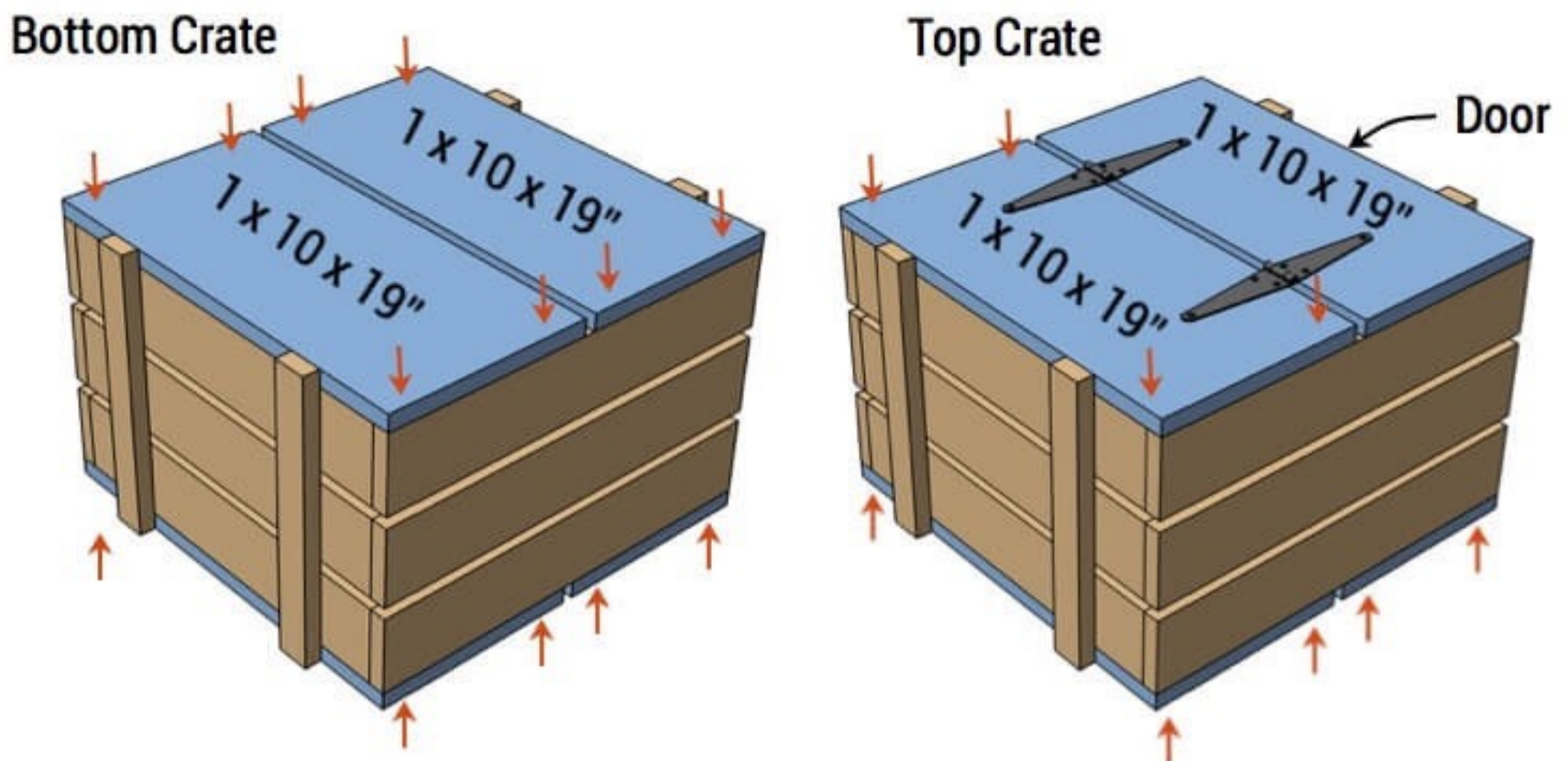

Install tops and bottoms using **1-1/4" wood screws**.
Then install hinges using hardware included.



Step 4: Final Assembly

Assemble side table
as shown using
1-1/4" wood screws.

